

Product Data Sheet

GAH50S Type Swivel Gauge Adaptor



Key features

- Allows 360° positioning of gauges on site
- A wide range of connection sizes and alternative materials available upon request

General Arrangement Drawing

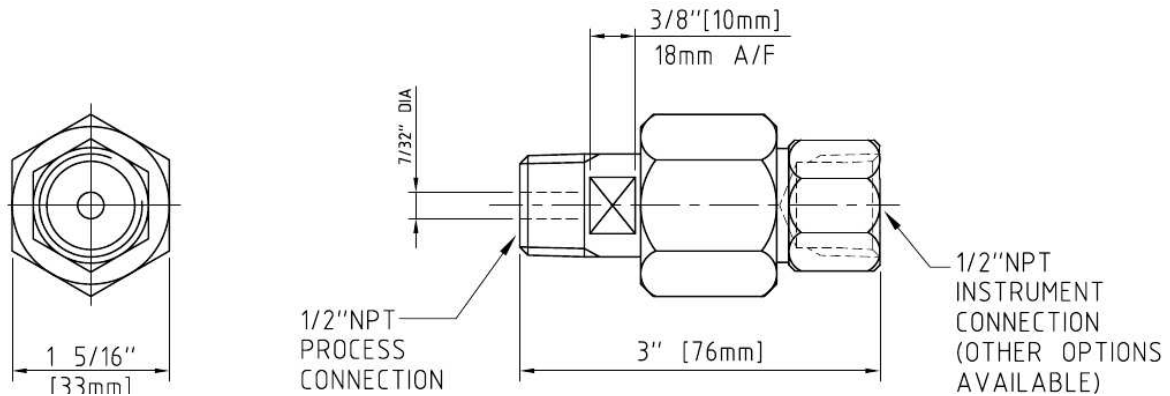

Max Pressure	10,000 PSI
Standard Material	316 Stainless steel
Standard Connections	½" NPT male X female
Max Temperature	540°C
Seals	Metal

Rev 1.2